



PRODUCT RELEASE DOCUMENT



SNOWDOZER



PRODUCT DESCRIPTION



'For businesses with large premises and car parks, Snowdozer is the most cost-effective way of preventing costly closures in snowy conditions. That means that customers can make substantial cost savings by being productive when other businesses have to close or pay contractors to clear the site for them.'

Snowdozer offers customers a cost-effective solution to keep their business open in even the harshest wintery conditions. The 1750mm wide, angled plough blade provides maximum dispersion of heavily built-up snow allowing the cleared area to be easily gritted ensuring the site is safe. The plough can be attached to any standard forklift forks and therefore offers an ideal solution for sites which operate forklift trucks. It means that the customer can manage their own site clearance and avoid using specialist contractors to clear the site for them.

The Snowdozer comes in standard with a yellow frame and black blade which is also available as a spare should both sides of the blade get worn. NB. For European markets we would recommend the Snowdozer be attached upside down.

KEY BENEFITS

1. Keeps businesses open and operating during snowy winter conditions.
2. On-site solution to allow customers to manage their own site without the need for contractors.
3. Long product lifespan means cost is spread over years.
4. Simple and reliable so the product can always be used.

PROJECT BACKGROUND



Winter weather patterns in the UK are unpredictable and with recent record levels of snowfall in 2009 businesses are looking to be prepared for further harsh winters. Following customer demand for a solution to help them clear their sites in heavy snow conditions, the Snowdozer is being launched to offer customers a complete winter safety package to keep people safe and businesses productive.

TECHNICAL INFORMATION



Materials:

Front Blade	Durapol®
Blade Backing Strip	Armortec™ Coated Steel
Framework	Armortec™ Coated Steel

Colour:

FRAME	Golden Yellow	RAL1004
BLADE	Black	

Dimensions:

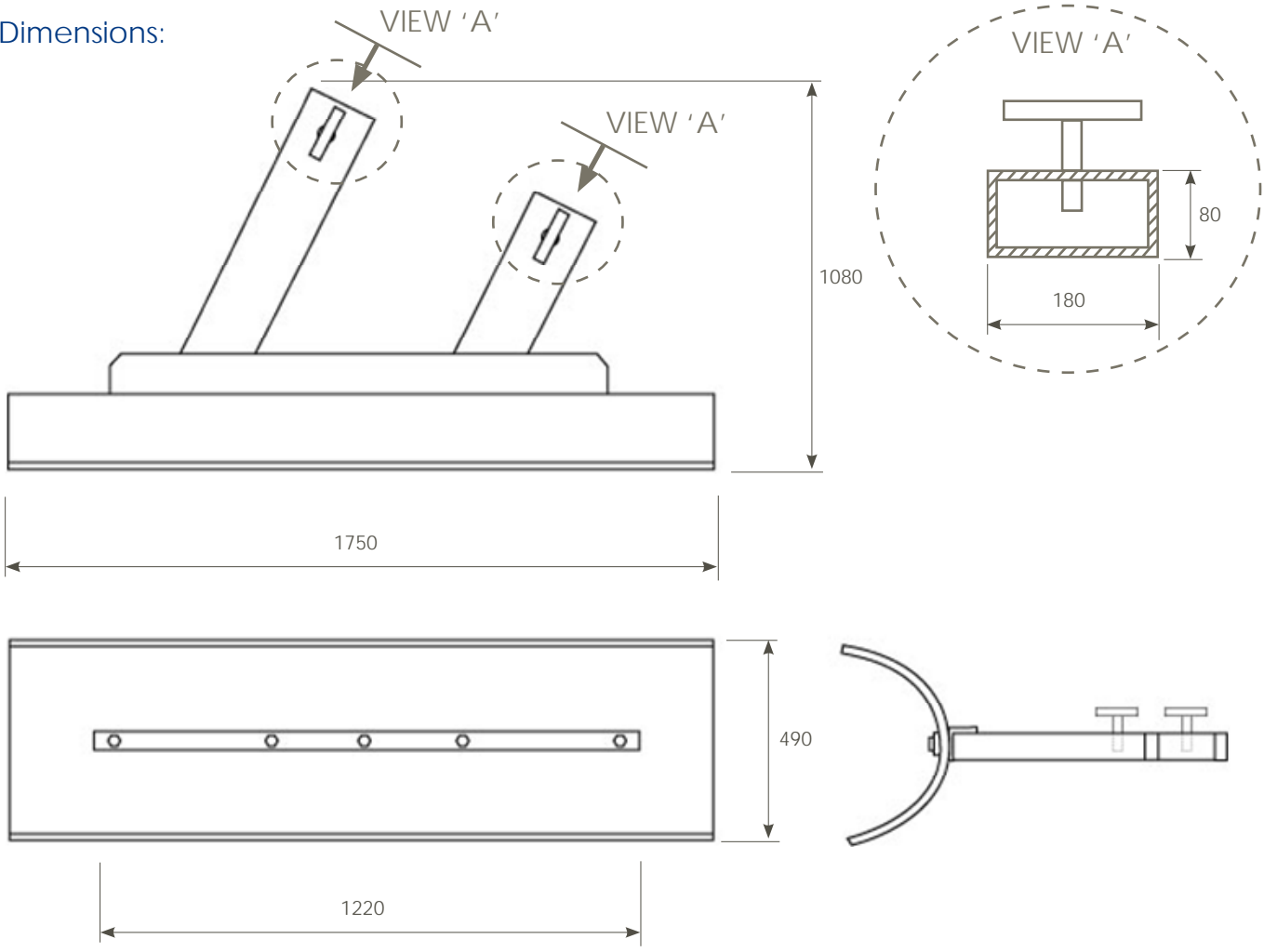

All dimensions in mm

BLADE	Width	1750mm
	Internal Diameter	630mm
	Thickness	15mm
	Angle of Sweep	25° to the left
FRAME	Right Arm Length	700mm
	Left Arm Length	1000mm
	Width of Blade Support	1220mm
	Height of Blade Support	50mm



REVERSIBLE DURAPOL® BLADE

1750mm Blade

Provides a large clearing width for maximum ploughing effectiveness.

25° Angled Blade

Safe snow removal as snow is pushed to side of road.

Low Friction Material

Increases ploughing efficiency and prevents build-up of snow on the blade.

Removable Blade

Double usable lifespan.

Robust & Impact Resistant

Long lifespan in cold conditions.

Corrosion Resistant

Minimises maintenance costs.

Easy to Clean

Impervious and easily wiped clean of grit, snow and dirt.



TWIST LOCKS

Simple Screw Action

Easy operation and can be operated with gloves on.

Robust Screw Thread

Reliable fixing method operates in all weather conditions.



PRODUCT FEATURES



UNIVERSAL FORK MOUNTING

Universal Fitting

Fits all standard forklift forks.

Robust Housing

Minimises risk of damage to mounting points so product is always usable.

Wide Access Mounting Arm

Makes mounting quick and simple for forklift driver.



ARMORTEC™ COATED FRAME

Robust & Impact Resistant

Scratch resistant and can withstand malicious damage.

Corrosion Resistant

Minimises maintenance costs.

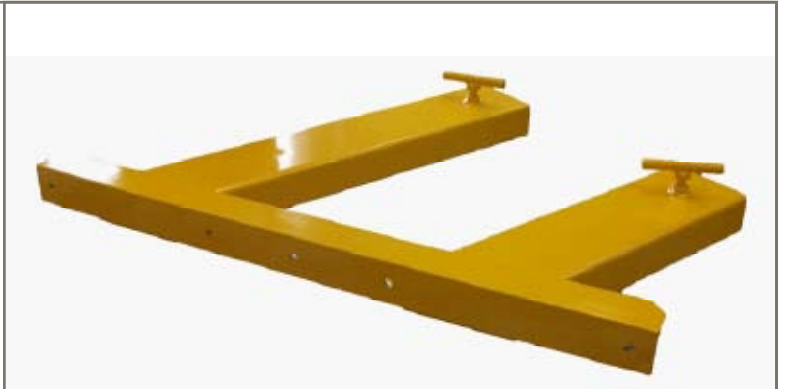

FORKLIFT FORK STOPS

Internal Steel Bump Stops

Prevent damage to the product or the forklift and indicate when the forks are fully engaged with the mounts.

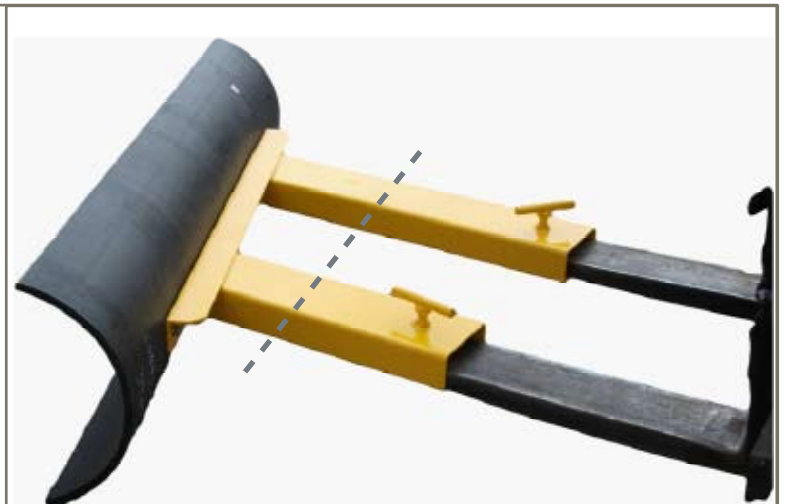

BRANDING AND COLOUR RANGE



BRANDING

A sticker with the product name and GML company details is adhered to the longer of the two fork mounting arms.



COLOUR RANGE

The product comes in Glasdon Golden Yellow Armortec coated paint finish with a self coloured Black Duropol Blade.



Alternative colours will be subject to minimum order quantities.

The minimum order quantity for Glasdon standard colours is 20. Purchasing/Technical Services are to be contacted to confirm the minimum order quantity before the customer is advised.

For all special colours a typical minimum order quantity will be in the region of 40 - refer to Technical Services.

PERSONALISATION

Personalisation is not available on this product.