

ISC-30/25 CIRCULAR IGLOO



Contenur's crane-lift igloos have been designed so they fit perfectly into the urban environment, with a wide range of customised solutions for each type of waste collection: glass, paper, plastics, etc.

They are manufactured from solid-coloured high density linear polyethylene and are stabilised against the combined effects of UV radiation and water, making this a low maintenance product which is highly resistant to atmospheric conditions.

Contenur offers four different crane lift Igloo models: the

ISC-30/25 (2500 and 3000 litre), the ISR-25 (2500 litre), the ISR-3200 (3200 litre) and the ISR-32V (3200 litre).

Contenur designs and manufactures its containers in accordance with Quality Management certification ISO 9001, and the Environmental Management certification ISO 14001.

The Contenur Group guarantees the quality of all its products and units, and on client request can also offer a complete product maintenance programme. For more information, please contact our Technical Sales network.

ISC-30/25 CIRCULAR IGLOO

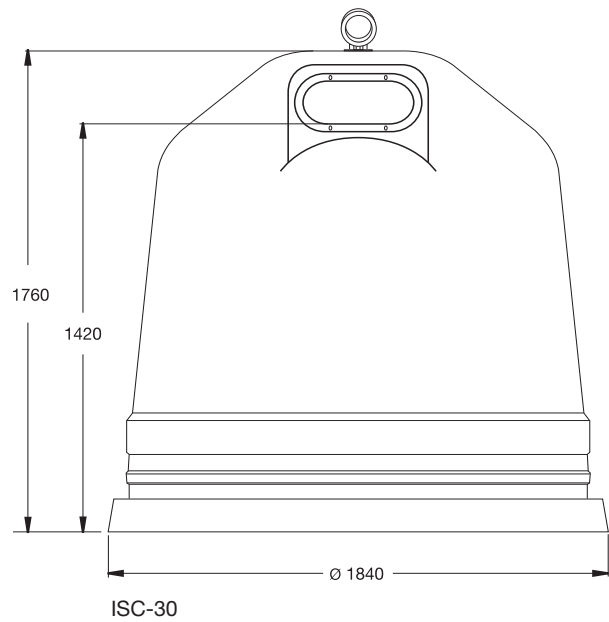
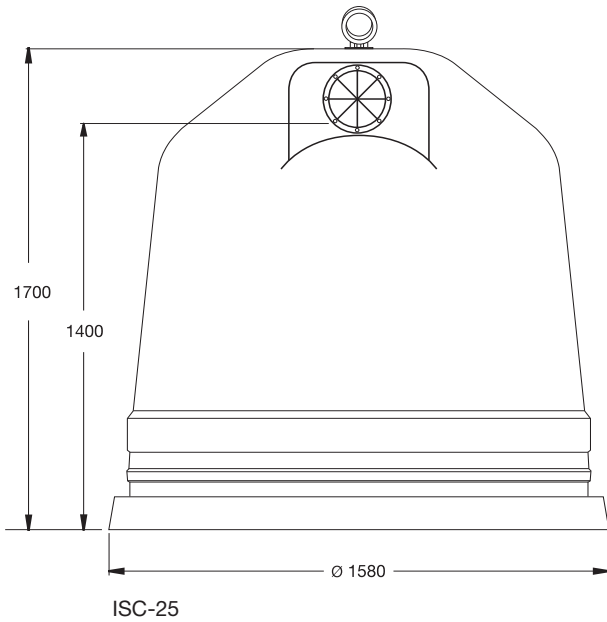

TECHNICAL SPECIFICATIONS

	ISC-25	ISC-30
NOMINAL CAPACITY	2,500 litres	3,000 litres
TOTAL WEIGHT	670 kg	850 kg
NOMINAL LOAD	580 kg	750 kg
MAXIMUM DIM.	1.58 dia. x 1.70 high m	1.84 dia. x 1.76 high m
HEIGHT OF OPENING	1400 mm	1420 mm
DIAMETER OF OPENING	200 or 150 x 400 mm	200 or 150 x 400 mm

GENERAL SPECIFICATIONS

- They are manufactured from solid-coloured high density linear polyethylene and are stabilised against the combined effects of uv radiation and water, making this a low maintenance product which is highly resistant to atmospheric conditions.

- Smooth surfaces.
- Colour stability.
- Total corrosion resistance.
- Designed to have a small footprint and the minimum environmental impact.
- Customised containers for each type of waste collection: glass, paper, plastics, etc.
- Double hook or Kinshofer crane lifting system.
- Igloo shaped body with a base diameter of either 1.58 or 1.84 m, and a maximum height of 1.76m.
- Exclusively-designed Contenur outline brace, with a double dome on the upper part, making the assembly robust and hard-wearing.

- Optimum size apertures to take each type of waste, at a maximum height of 1.42 m from the ground, to facilitate user access. They can be circular (200 mm) or rectangular (150 x 400 mm), with a reinforced exterior and front overhang to prevent water ingress.

- Discharge doors manufactured from rotationally-moulded high density polyethylene (same as the body), with a double layer system for added strength. They pivot laterally and their wide, hinged opening facilitates unhindered emptying into the vehicle.
- The lifting/ emptying system is corrosion resistant steel and is located on the upper part of the container.
- The following items are available upon request: large size apertures with a lock, silk screen graphics incorporated onto the container during the manufacturing process, personalised colour, reflective strips etc.